



# **NEWMAN Sanitary Gasket Company**

P.O. Box 222, Lebanon, Ohio 45036 ▪ 513.932.7379 ▪ Fax 513.932.4493 ▪ [www.newmangasket.com](http://www.newmangasket.com)

## **Instruction Manual And Limited Warranty**

### **Newman NewFlo™ Replacement Diaphragms NIT Series – For ITT® Pure-Flo® Valves<sup>i</sup>**

#### Warning:

Newman NewFlo™ Replacement Diaphragms are designed and fabricated using quality workmanship and materials which comply with applicable industry standards. They should only be used under the supervision of and in applications recommended by a company engineer which are appropriate for the nature of the materials employed. Misapplication or misuse of this product could result in injury or property damage.

Diaphragms must be matched to the particular valve for which they were designed and be installed in accordance with the Original Equipment Manufacturer's (OEM) installation instructions unless otherwise specified herein. Regular maintenance and operational limits of the individual valves still apply. Diaphragm materials must only be used in the physical and chemical environments for which they were designed. If leakage occurs, replacement of the diaphragm or repair/replacement of the valve may be necessary.

This manual is not intended to cover the overall safe installation and operation of valves, but only to advise the end user on the installation of NewFlo™ Replacement Diaphragms. This information is provided to the end user in good faith but does not constitute an assumption of liability from either the OEM or the end user to Newman Sanitary Gasket Company (NSG) for the operation of the end user's system. See Section 4.0 for limits of liability.

#### Contents:

This manual contains installation and maintenance instructions for Newman NewFlo™ Replacement Diaphragms. If additional information is required, please contact:

Newman Sanitary Gasket Company  
PO Box 222  
Lebanon, OH 45036  
(513) 932-7379  
Fax (513) 932-4493  
Attn: Customer Service

#### 1.0 Safety Precautions



Only suitably trained and qualified personnel should be used in the installation, inspection and operation of sanitary valves and their components. It is the responsibility of the operating company to precisely define their responsibilities and to see to the training and competency of

such personnel. It is further the responsibility of the operating company to ensure that the contents of the OEM manual and this manual are understood by these personnel, including all safety information.

Failure to follow all indicated safety precautions and procedures (including all relevant national, local, and company specific safety regulations, policies, and procedures) can result in injury, property and process loss and/or damage to the environment. Designers, plant contractors and those who operate their systems remain responsible for the proper maintenance and use of diaphragm valves.

### 1.1 Valve Disassembly Safety – Don't Risk Injury or Death!



**CAUTION: Depressurize Lines!** Although diaphragms may be replaced without removing the valve from the process piping, ensure that the valve has been removed from service and any pressure in adjacent piping is released before performing any work. Injury may result from disassembly of a pressurized valve. Process lines must be flushed, drained and depressurized before replacing a valve diaphragm. Even after depressurizing a system, slowly loosen the retaining bolts to allow gradual pressure equalization. Upon replacement of the diaphragm, immediately refit and activate all safety and protective equipment.

**CAUTION: Cool Down Lines!** Even in cleaned lines, the valve components may be hot. Only replace valve diaphragms after the temperature of the valves has equalized to ambient.

**CAUTION: Beware of Chemical Emissions and Contact!** Hazardous chemicals should be neutralized before diaphragm replacement. Appropriate protective clothing, equipment and ventilation should be used to avoid exposure to chemicals and their vapors. Know your system and what was in the line prior to valve disassembly. Know what contaminants might be on the valve from any leakage.

### 1.2 Diaphragm Limits

Newman NewFlo™ Replacement Diaphragms were designed, manufactured, and tested for normal loads under relevant pressure equipment standards. They assume normal media dependant flow rates, temperature gradients, and pressure ratings, and offer no additional explosion protection or protection from excessive influencing factors from the piping or external forces. Operational limits of the diaphragms and valves should always be considered before and during use.

### 1.3 Transport and Storage

Replacement Diaphragms may only be transported by means appropriate to local regulations and relevant technical standards to prevent accidents.

#### 1.3.1 Transport

The diaphragms should be carefully handled to prevent damage in shipment. Excessive or deep scratches may result in leakage. Damage to diaphragm studs may result in damage to the valve.

### 1.3.2 Unpacking

Unpack the shipment and check the contents to ensure that nothing is damaged or missing.

### 1.3.3 Storage

Should the diaphragm not be installed immediately, store properly. Storage should be in original packaging in a dry room with a consistent temperature between 15°C and 40°C. Avoid UV rays and direct sun. Although the sealed tamper-resistant packaging is designed to mitigate exposure to high humidity, storage over long periods of time in high humidity may require moisture-proof over-packing.

### 1.3.4 Disposal, Recycle, or Return Shipment

Disposal, Recycling or Return Shipments must comply with local, state and federal law and be processed by qualified personnel.



Should return be necessary, contact the manufacturer at the contact information listed in this manual for specific instructions. It is the operator's responsibility to ensure that all aggressive, toxic, caustic or otherwise harmful materials have been completely removed from the diaphragm before return, recycling or disposal. MSDS's of relevant substances used in the process stream of the valve are required with the return of any item to the manufacturer.

## 2.0 Installation

Unless otherwise specified in this manual, install, assemble and disassemble valves as directed by the Original Equipment Manufacturer (OEM). Proper design, drainage and welding must be considered in every application. Proper safety procedures should be followed as directed by qualified personnel and as stipulated in relevant national, state, local and operating company regulations and standards, in addition to this and OEM manuals.

### 2.1 Diaphragm Replacement

1. Safely clean, cool and depressurize the line containing the valve using proper safety procedures.
2. Remove the bonnet nuts and bolts gradually loosening by following the diagonally opposing technique as shown in Figure 1.

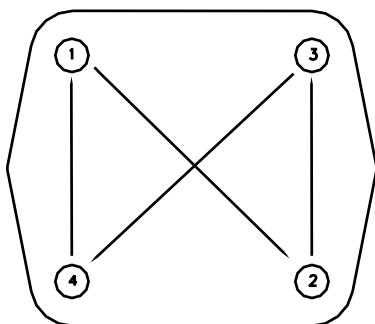

Figure 1 – Diagonally Opposing Pattern:  
Gradually loosen nuts as shown.

3. Lift off the bonnet and unscrew the old diaphragm by rotating it counter-clockwise.
4. Check to make sure that the replacement diaphragm is the same size and material as the old diaphragm. See OEM manual for help in identifying the old markings. NSG diaphragm marks can be found in Figure 2 below. Two piece and one piece diaphragms are not interchangeable on ITT® diaphragm valves (see OEM Literature).

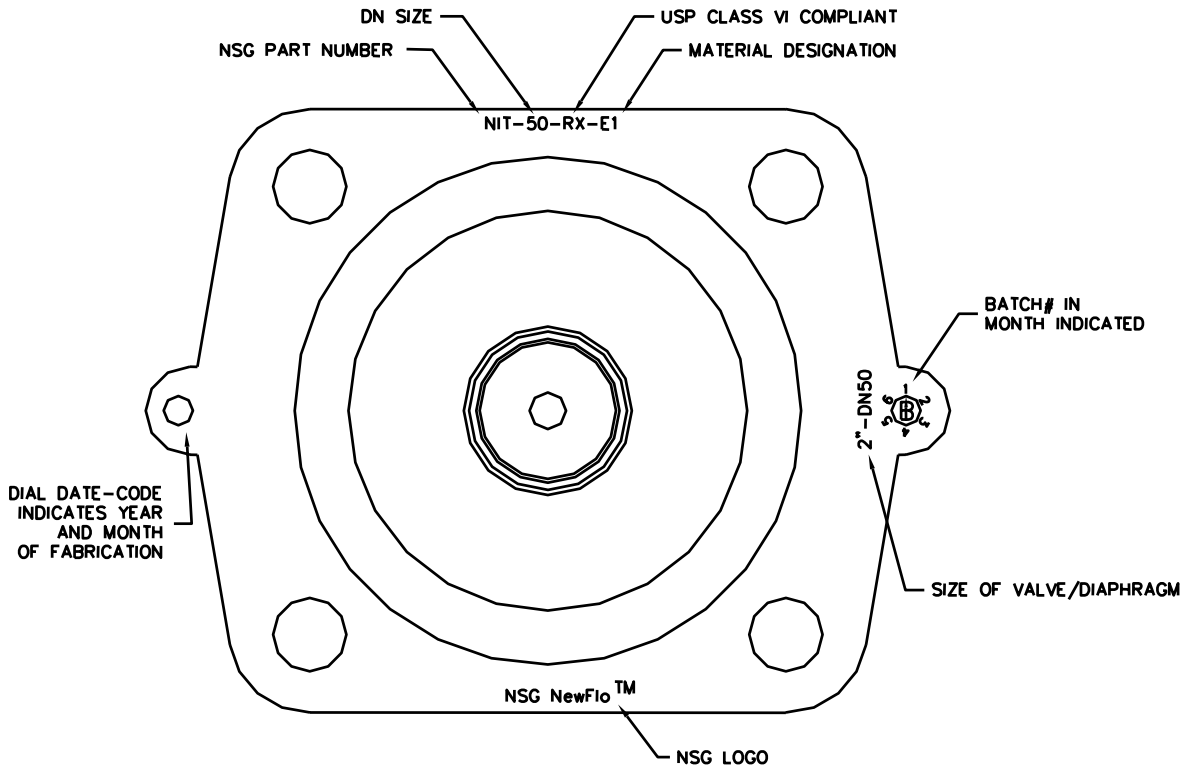

FIGURE 2 – Identifying the Diaphragm

Newman Part Numbering System:  
E.g.: NIT-50-RX-E1G1

<u>N</u>	<u>IT</u>	<u>50</u>	<u>RX</u>	<u>E1</u>	<u>G1</u>	<u>(-S)</u>
<i>Newman</i>	<i>ITT®-Style</i>	<i>DN (Iso) Size</i>	<i>USP Class VI</i>	<i>Backing Matl. Type E - EPDM</i>	<i>Weir Matl. Type G-TFM</i>	<i>If present Single Piece</i>

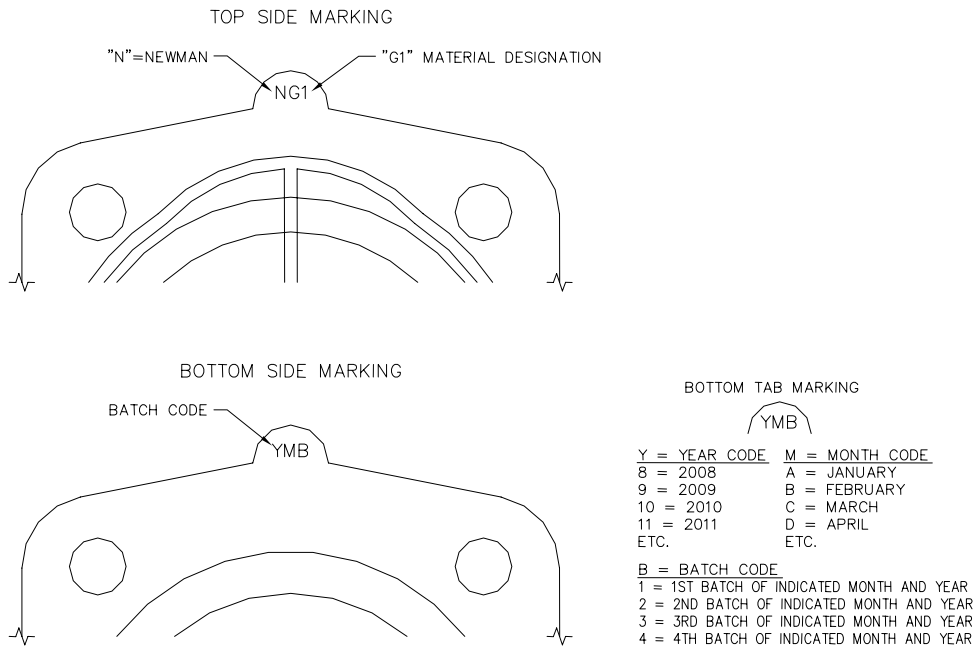

FIGURE 3 – Weir Marking System

5. Inspect the valve assembly according to OEM and company standard procedures before re-assembly. Replace/repair any worn or defective parts as required.
6. Insert the NSG Newflo™ Diaphragm weir stud through the Elastomer Backing and thread it into the valve compressor as shown in Figure 3, rotating the weir clockwise until hard stop or heavy resistance is felt. The compressor should be fully extended to reduce the friction from the Weir/Elastomer Backing Interface (See OEM manual for additional information). Newman does not recommend inverting the weir during installation.

After hand tightening the weir, rotate the backing and weir back counter-clockwise as little as necessary (1/2 turn) to line up the Bonnet Bolt holes. Failure to completely screw in the weir can result in failure of the weir at the stud/valve body interface. Over-torquing the weir can result in damaging the threads of the diaphragm and/or valve.

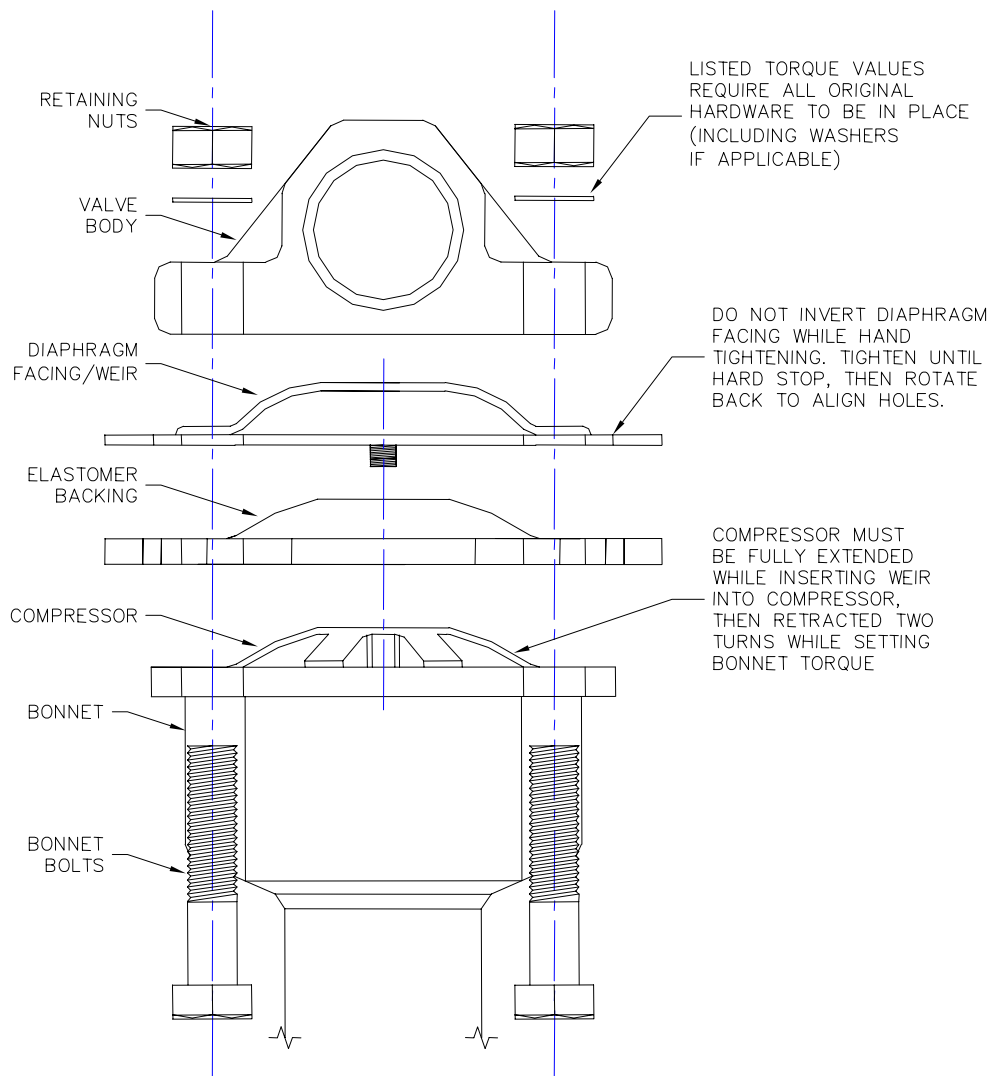

Figure 3 – Diaphragm Installation

7. After installing the weir onto the valve compressor, retract the compressor by rotating the actuator counterclockwise until the Diaphragm Weir/Backing combination is pressed against the bonnet (about 1-2 full turns). Install the bonnet bolts and hardware and torque to the values listed in Table 1 following the diagonally opposing pattern shown in Figure 1. NOTE: As hardware and bonnet configurations vary, NSG recommends that the diaphragm be installed to minimum torque values as recommended in the relevant OEM literature. If leakage occurs at the diaphragm/valve body interface, torque should be increased until no leakage is observed. If leakage still occurs at the highest OEM listed value, contact NSG and return the diaphragm for replacement. Torque Values listed are from the ITT® PureFlo® Instruction Manual PFMM-08 Rev 1 for specified Handwheel Bonnets. Current versions of the OEM manual for each individual valve should be consulted and specific direction given by the plant engineer for each application. Diaphragm longevity may be increased at lower torque values.

Size	PAS Bonnet Bolt Torque in-lbs (N-m)	
	Two Piece TFM	Single Piece Elastomer
0.5" - DN15	20 (2.3) – 50 (5.7)	20 (2.3) – 40 (4.5)
0.75" - DN20	40 (4.5) – 70 (7.9)	20 (2.3) – 50 (5.7)
1" - DN25	45 (5.1) – 80 (9.1)	25 (2.8) – 70 (7.9)
1.5" - DN40	145 (16) – 170 (19)	75 (8.5) – 130 (14.7)
2" - DN50	225 (25) – 275 (31)	100 (11) – 180 (14.7)
Size	Metal Bonnet Bolt Torque in-lbs (N-m)	
	Two Piece TFM	Single Piece Elastomer
0.5" - DN15	25 (2.8) – 80 (9.1)	20 (2.3) – 40 (4.5)
0.75" - DN20	50 (5.7) – 80 (9.1)	20 (2.3) – 50 (5.7)
1" - DN25	65 (7.4) – 120 (13.6)	45 (5.1) – 70 (7.9)
1.5" - DN40	200 (23) – 225 (25)	75 (8.5) – 130 (14.7)
2" - DN50	225 (25) – 300 (34)	100 (11) – 180 (20)

Table 1 – Bonnet Bolt Torque Values

**Table 1 Notes:**

1. Make multiple passes using the diagonally-opposing pattern shown in Figure 1 to gradually tighten the Bonnet Bolts.
2. Torque Values are from ITT PureFlo® Instruction Manual PFMM-08 Rev 1. Current Versions of the OEM Manual for each specific valve should be consulted and specific direction given by the plant engineer for each application.



Prior to pressurization (with the valve open), the bonnet bolts must be fully torqued according to the diagonally opposing pattern in Figure 1 and Table 1 with the valve slightly open. Retightening the bolts appropriately at ambient conditions after a full pressure/temperature cycle is also advised. If leakage occurs at the diaphragm/valve body interface, immediately depressurize the system and retorque appropriately. If leakage continues, inspect the valve for defects and replace the diaphragm as necessary.

## 8. Single Piece Elastomer Diaphragms

Single Piece Elastomer Diaphragms follow the same procedures described above with the exception that they do not possess a backing.

## 9. Travel Stop Adjustment

Diaphragms often need a different Travel Stop adjustment to prevent over closing the valve and to prolong diaphragm life. The Travel Stop should be adjusted at the time of installation. See the OEM manual for procedures in adjusting the Travel Stop.

## 3.0 Periodic Inspection

Diaphragms Valves should be periodically inspected per OEM and operating company requirements and schedules. Replace worn or defective parts immediately using all applicable safety procedures for containing process fluids, heat and pressure. Note cautionary statements in OEM literature and Section 1 and 2 above.

## 4.0 LIMITATION OF LIABILITY

*Due to the complexity and diversity of their use, NSG can make no claims to the length of service of NewFlo™ diaphragms in the operating company's systems and NSG chooses to limit its total liability in all circumstances to the replacement cost of any NewFlo™ diaphragms found to be defective in material or workmanship.*

---

<sup>i</sup> ITT® is a registered trademark of ITT Manufacturing Enterprises, Inc. PureFlo® is a registered trademark of ITT Corporation. Newman Sanitary Gasket Company (NSG) does not manufacture or sell ITT® OEM valves or diaphragms. NSG is not affiliated with ITT Manufacturing Enterprises, Inc. and/or ITT Corporation, nor is NSG or any of its products sponsored by or endorsed by either of these companies.